



TEST REPORT

NO.: A002E11110234-1R01

Date: Nov. 10, 2011

Page 1 of 14

Customer: Nantong Fujitsu Microelectronic Co., Ltd

Address: No.288, Chongchuan Road, Nantong, Jiangsu, China

Report on the submitted sample said to be

Sample name: LQFP100-NT

Model: /

Item/Lot No.: /

Material: /

Buyer: /

Supplier: /

Manufacturer: /

Sample received date: Nov. 02, 2011

Testing period: From Nov. 02, 2011 to Nov. 10, 2011

Testing Requested:

1. As specified by client, to determine the Lead, Cadmium, Mercury, Hexavalent Chromium, PBB & PBDE, PCB, PCN, PCT, Other chlorinated organic compounds, SCCP, Other brominated organic compounds, HFC, FPC, Asbestos, Formaldehyde, TBT, TPT, DBT, DOT, DEHP, DBP, BBP, DIBP, DINP, DNOP, DIDP and DNHP, Specific AZO compounds, Polyvinyl chloride (PVC) and PVC blends, Beryllium oxide and Beryllium copper, Perfluorooctane sulfonates (PFOS), Dimethyl fumarate (DMF), Ozone-depleting substances (ODS), Cobalt dichloride, TCEP, HBCDD, Specific benzotriazole, Diarsenic trioxide, Diarsenic pentaoxide, Boric acid, Specific sodium borates content in the submitted sample in accordance with SS-00259 tenth edition.
2. As specified by client, to determine the PFOA content in the submitted samples in accordance with POHS.
3. As specified by client, to determine the Fluorine, Chlorine, Bromine and Iodine content in the submitted sample.
4. As specified by client, to determine the Antimony content in the submitted sample.

Results:

Please refer to the next pages.

*****FOR FURTHER DETAILS, PLEASE REFER TO THE FOLLOWING PAGE(S)*****

Project Leader
(Engineer)

Maggie

Approved by
(Lab manager)

Mickey

Inspected by
(Technical manager)

Weikin

TEST REPORT

NO.: A002E11110234-1R01

Date: Nov. 10, 2011

Page 2 of 14

Testing method:

Testing Item	Pretreatment method	Measuring instrument
Lead (Pb)	IEC 62321: 2008, section 8/9	ICP-OES
Cadmium (Cd)	IEC 62321: 2008, section 8/9	ICP-OES
Mercury (Hg)	IEC 62321: 2008, section 7	ICP-OES
Chromium (Cr VI)	IEC 62321: 2008, Annex B/C	UV-VIS
PBBs/ PBDEs	IEC 62321: 2008, Annex A	GC-MS
PFOA	US EPA 3550C: 2007	GC-MS
Fluorine/ Chlorine/ Bromine/ Iodine	BS EN 14582: 2007	IC
Antimony (Sb)	US EPA3050B: 1996	ICP-OES
PCB/ PCN/ PCT/ SCCP/	US EPA 3540C: 1996	GC-MS
Asbestos	NIOSH 9000	XRD
Formaldehyde	JIS A 5905	UV-VIS
TBT/ TPT/ DBT/ DOT	DIN EN ISO 17353:2005	GC-MS
DEHP, DBP, BBP, DIBP, DINP, DNOP, DIDP, DNHP	US EPA 3550C:2007	GC-MS
Specific AZO compounds	EN 14362-1: 2003	GC-MS
Polyvinyl chloride (PVC) and PVC blends	ASTM D2124-99	FTIR
Beryllium /Beryllium oxide / Beryllium copper	US EPA3052:1996	ICP-OES
Cobalt/Cobalt dichloride	US EPA3052:1996	ICP-OES
Perfluorooctane sulfonates (PFOS)	US EPA 3540C: 1996	LC
Dimethyl fumarate (DMF)	US EPA 3540C: 1996	GC-MS
TCEP	US EPA 3540C: 1996	GC-MS
HBCDD	US EPA 3540C: 1996	GC-MS
Specific benzotriazole	US EPA 3540C: 1996	GC-MS
Diarsenic trioxide	US EPA3052:1996	ICP-OES
Diarsenic pentaoxide	US EPA3052:1996	ICP-OES
Boric acid、 Specific sodium borates	US EPA3052:1996	ICP-OES
HFC/ PFC/ Other chlorinated organic compounds/ Other brominated organic compounds/ Ozone-depleting substances (ODS)	US EPA 5021	HS-GC-MS

TEST REPORT

NO.: A002E11110234-1R01

Date: Nov. 10, 2011

Page 3 of 14

Test Flow:

1. To Determine Lead, Cadmium Content (for Polymer):

Tested by: *Condy*

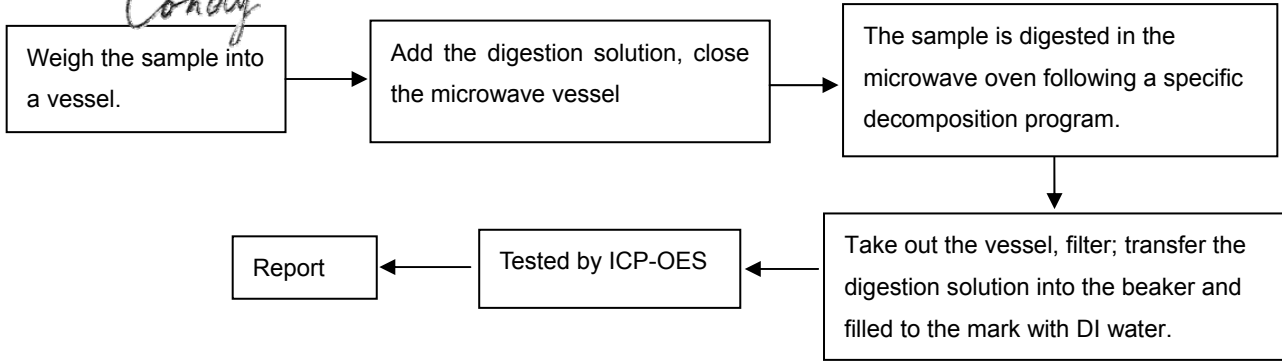

2. To Determine Lead, Cadmium Content (for metal):

Tested by: *Condy*

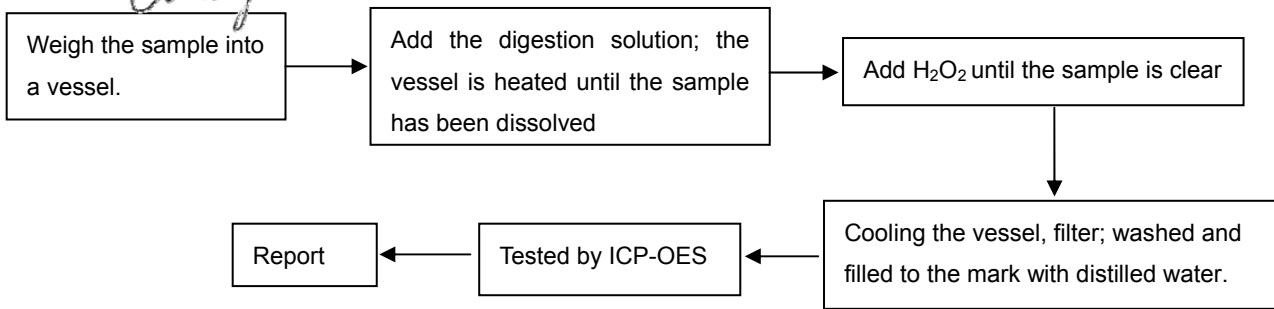

3. To Determine Mercury Content:

Tested by: *Condy*

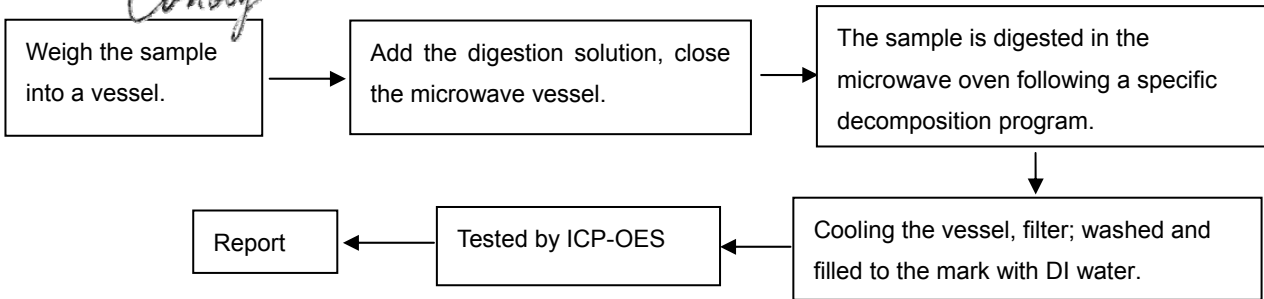

TEST REPORT

NO.: A002E11110234-1R01

Date: Nov. 10, 2011

Page 4 of 14

4. To Determine Hexavalent Chromium Content (for Polymer):

Tested by: *Danae*

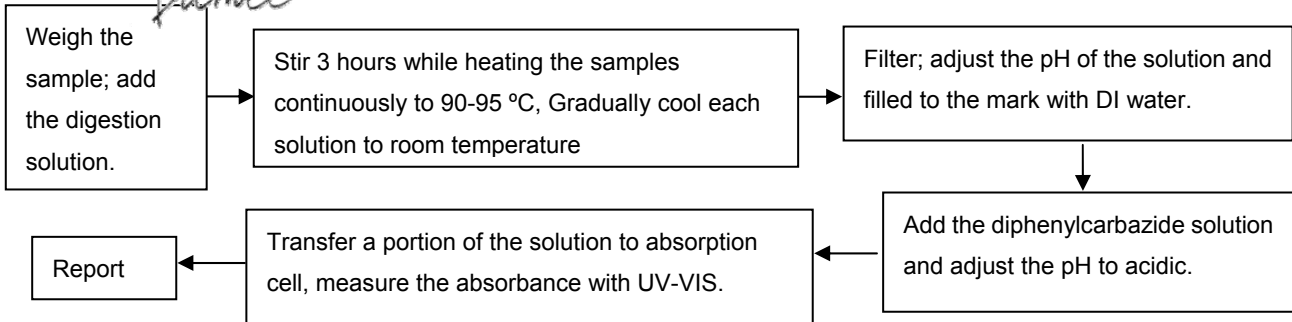

5. To Determine Hexavalent Chromium Content (boiling- water- extraction) in metals:

Tested by: *Danae*

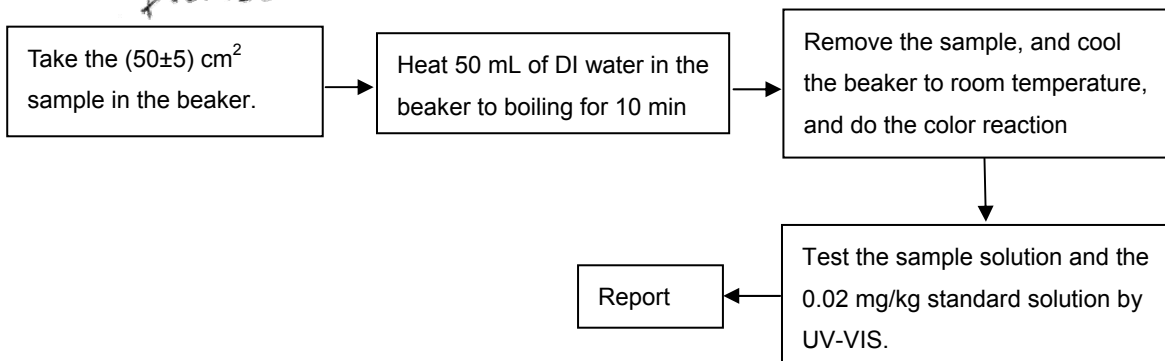

6. To Determine PBBs/PBDEs, PFOA, PCB, PCN, PCT, Other chlorinated organic compounds, Other brominated organic compounds, SCCP, HFC, FPC, DMF and Content:

Tested by: *Carina*

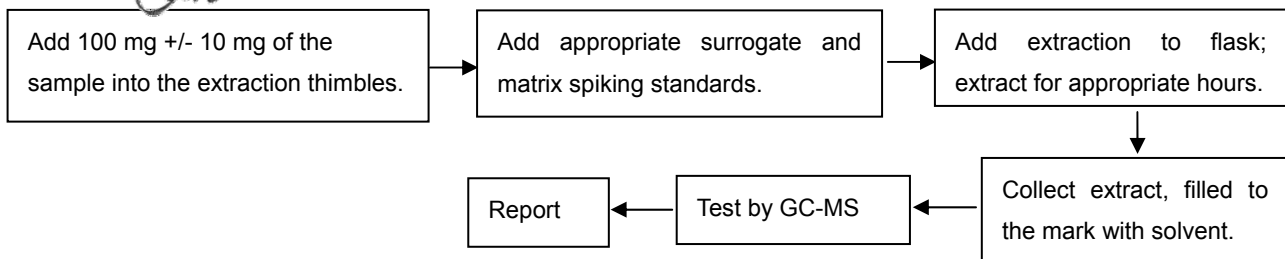

TEST REPORT

NO.: A002E11110234-1R01

Date: Nov. 10, 2011

Page 5 of 14

7. To Determine TBT, TPT, DBT, DOT Content:

Tested by: *Carina*

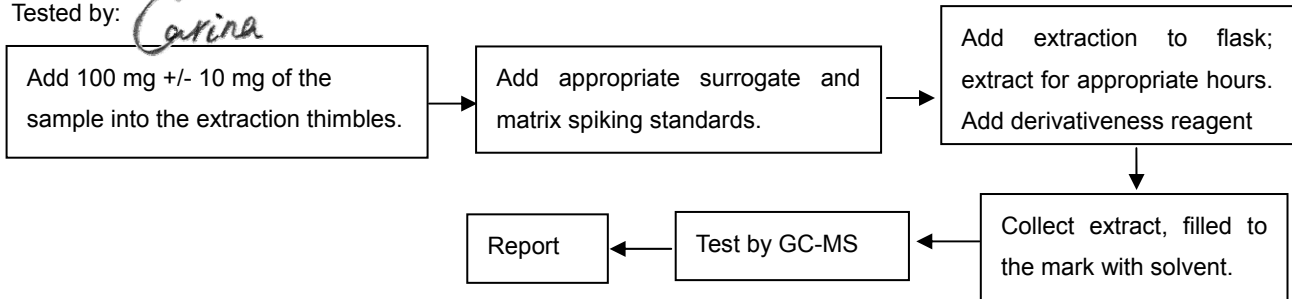

8. To Determine DEHP, DBP, BBP, DIBP, DINP, DNOP, DIDP, DNHP Content:

Tested by: *Carina*

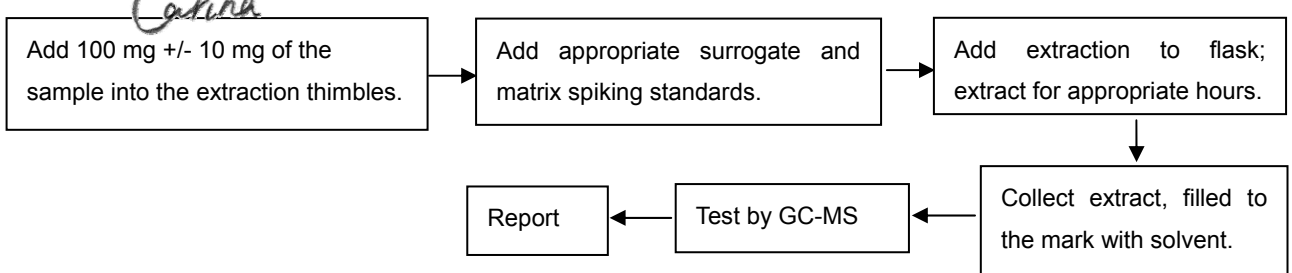

9. To Determine Beryllium, Cobalt Content:

Tested by: *Condy*

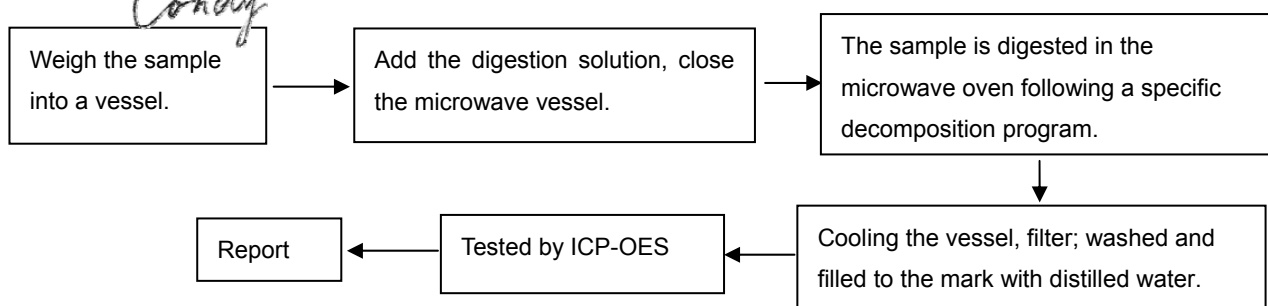

10. To Determine PFOS Content:

Tested by: *Carina*

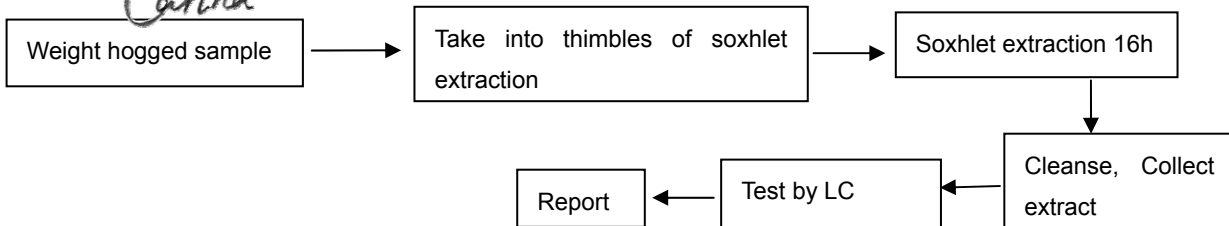

TEST REPORT

NO.: A002E11110234-1R01

Date: Nov. 10, 2011

Page 6 of 14

11. To Determine Specific benzotriazole Content:

Tested by: *Carina*

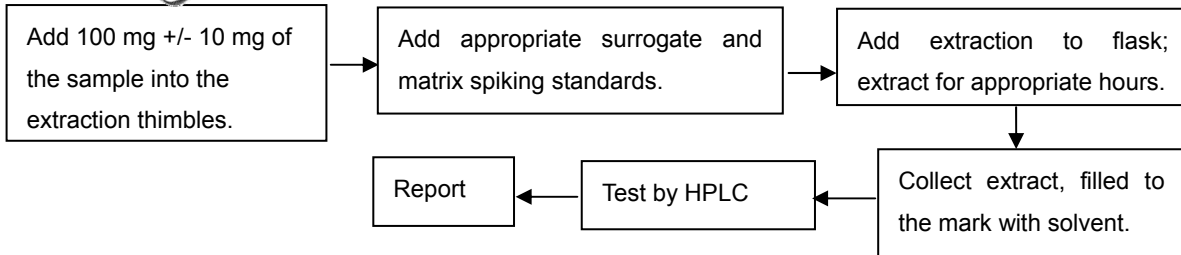

12. To Determine HBCDD Content:

Tested by: *Carina*

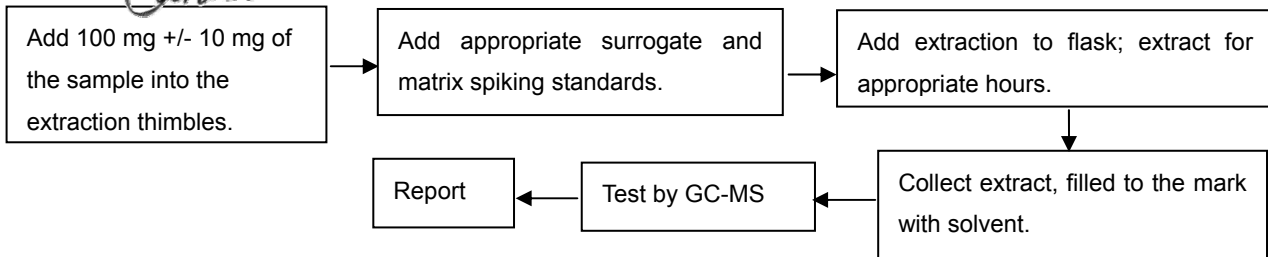

13. To Determine Fluorine, Chlorine, Bromine and Iodine Content:

Tested by: *Jason*

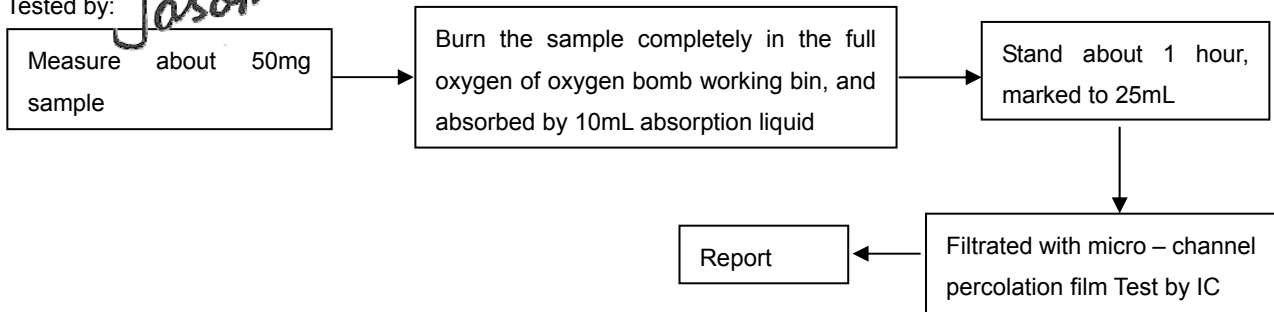

14. To Determine Antimony Content:

Tested by: *Condy*

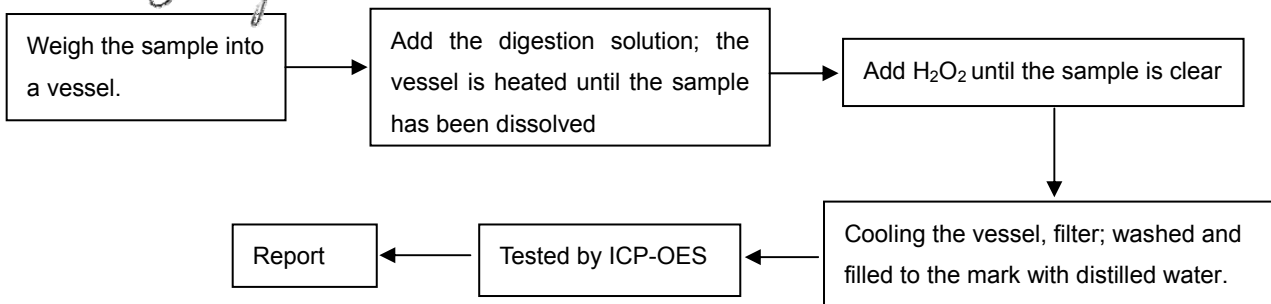

TEST REPORT

NO.: A002E11110234-1R01

Date: Nov. 10, 2011

Page 7 of 14

Test Results:

Item	Unit	MQL	Acceptable Limit	Results	
				1	2
Lead (Pb)	mg/kg	2	100	N.D.	N.D.
Cadmium (Cd)	mg/kg	2	5	N.D.	N.D.
Mercury (Hg)	mg/kg	2	1000	N.D.	N.D.
Chromium(CrVI)	mg/kg	2	1000	Negative	N.D.
Flame Retardants					
PBBs	mg/kg	--	/	/	N.D.
MonoBB	mg/kg	5	/	/	N.D.
DiBB	mg/kg	5	/	/	N.D.
TriBB	mg/kg	5	/	/	N.D.
TetraBB	mg/kg	5	/	/	N.D.
PentaBB	mg/kg	5	/	/	N.D.
HexaBB	mg/kg	5	/	/	N.D.
HeptaBB	mg/kg	5	/	/	N.D.
OctaBB	mg/kg	5	/	/	N.D.
NonaBB	mg/kg	5	/	/	N.D.
DecaBB	mg/kg	5	/	/	N.D.
PBDEs	mg/kg	--	/	/	N.D.
MonoBDE	mg/kg	5	/	/	N.D.
DiBDE	mg/kg	5	/	/	N.D.
TriBDE	mg/kg	5	/	/	N.D.
TetraBDE	mg/kg	5	/	/	N.D.
PentaBDE	mg/kg	5	/	/	N.D.
HexaBDE	mg/kg	5	/	/	N.D.
HeptaBDE	mg/kg	5	/	/	N.D.
OctaBDE	mg/kg	5	/	/	N.D.
NonaBDE	mg/kg	5	/	/	N.D.
DecaBDE	mg/kg	5	/	/	N.D.
Beryllium	mg/kg	2	/	N.D.	N.D.
Beryllium oxide*	mg/kg	/	/	N.D.	N.D.
Beryllium copper*	mg/kg	/	/	N.D.	N.D.
Perfluorooctane Sulfonates (PFOS)	mg/kg	10	See note	N.D.	N.D.

Note:

*Beryllium oxide and Beryllium copper test results are based on samples of Beryllium content of a conversion.

TEST REPORT

NO.: A002E11110234-1R01

Date: Nov. 10, 2011

Page 8 of 14

Item	Unit	MQL	Acceptable Limit	Results
				2
Polychlorinated biphenyls (PCB)	mg/kg	5	/	N.D.
Polychlorinated naphthalenes (PCN)	mg/kg	5	/	N.D.
Polychlorinated terphenyls (PCT)	mg/kg	5	/	N.D.
Other chlorinated organic compounds	mg/kg	5	/	N.D.
Short-chain chlorinated paraffins (SCCP)	mg/kg	5	1000	N.D.
Tris(2-chloroethyl) phosphate (TCEP)	mg/kg	5	1000	N.D.
Other brominated organic compounds	mg/kg	5	/	N.D.
Hydrofluorocarbon (HFC)	mg/kg	5	/	N.D.
Perfluorocarbon (PFC)	mg/kg	5	/	N.D.
Asbestos				
Amosite	%	1	/	Negative
Chrysotile	%	1	/	Negative
Crocidolite	%	1	/	Negative
Anthophyllite	%	1	/	Negative
Tremolite	%	1	/	Negative
Actinolite	%	1	/	Negative
Formaldehyde				
Formaldehyde	mg/L	0.02	/	N.D.
TBT	mg/kg	5	/	N.D.
TPT	mg/kg	5	/	N.D.
DBT	mg/kg	5	/	N.D.
DOT	mg/kg	5	/	N.D.
Di-iso-nonyl phthalate (DINP)	mg/kg	50	/	N.D.
Di-n-octyl phthalate (DNOP)	mg/kg	10	/	N.D.
Di (2-ethyl hexyl)-phthalate (DEHP) (DOP)	mg/kg	10	/	N.D.
Diisodecyl phthalate (DIDP)	mg/kg	50	/	N.D.
Butylbenzyl phthalate (BBP)	mg/kg	10	/	N.D.
Diisobutyl phthalate (DIBP)	mg/kg	10	/	N.D.
Dibutyl phthalate (DBP)	mg/kg	10	/	N.D.
Di-n-hexyl phthalate (DNHP)	mg/kg	10	/	N.D.
Dimethyl fumarate (DMF)	mg/kg	0.1	Absent	N.D.
Specific benzotriazole	mg/kg	5	/	N.D.
Cobalt	mg/kg	2	/	N.D.
Cobalt dichloride**	mg/kg	/	/	N.D.
PolyvinylChloride (PVC)***	/	/	/	Not detected

TEST REPORT

NO.: A002E11110234-1R01

Date: Nov. 10, 2011

Page 9 of 14

Note:

-**The substance is calculated by using the test results of element (Cobalt) respectively (testing instrument: ICP-OES)). If the sample contains total Cobalt, it needs further test the Chlorine (testing instrument: IC) content to make sure whether it includes Cobalt dichloride or not.

-***Infrared spectrogram of test sample and standard infrared spectrogram are included.

1. Infrared Spectrogram of Test Sample.

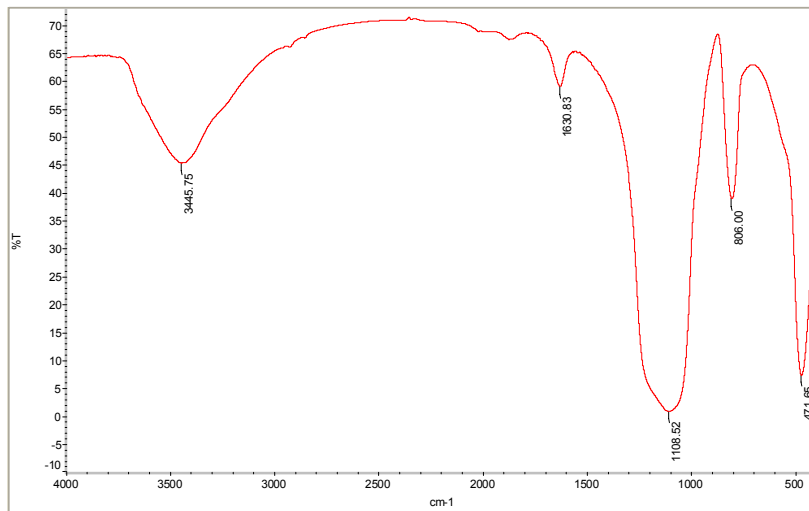

FT-IR

2. Standard Infrared Spectrogram

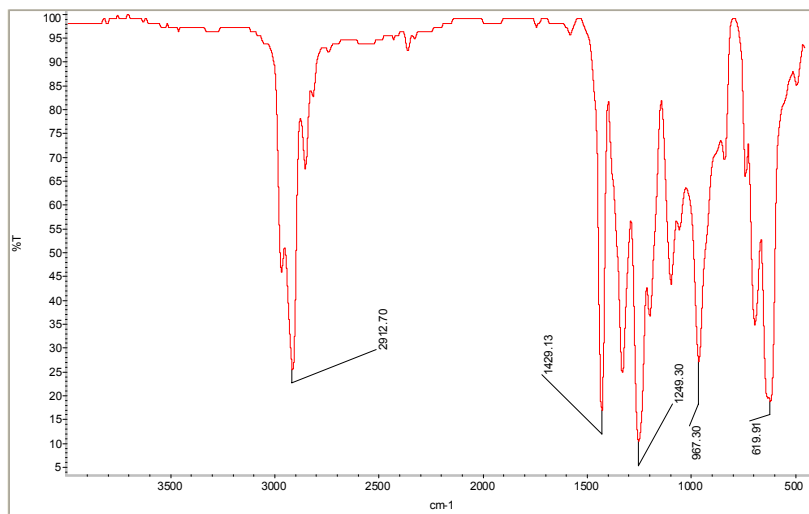

TEST REPORT

NO.: A002E11110234-1R01

Date: Nov. 10, 2011

Page 10 of 14

Amines Substances	Unit	MQL	Acceptable Limit	Results
				2
4-Aminobiphenyl	mg/kg	30	/	N.D.
Benzidine	mg/kg	30	/	N.D.
4-Chloro-2-methylaniline	mg/kg	30	/	N.D.
2-Aminonaphthalene	mg/kg	30	/	N.D.
4-Amino-2'-3-dimethylazobenzene	mg/kg	30	/	N.D.
5-nitro-o-toluidine	mg/kg	30	/	N.D.
4-Chloroaniline	mg/kg	30	/	N.D.
4-Methoxy-1, 3-phenylenediamine	mg/kg	30	/	N.D.
Bis- (4-aminophenyl) methane	mg/kg	30	/	N.D.
3,3'-Dichlorobenzidine	mg/kg	30	/	N.D.
3,3'-Dimethoxybenzidine	mg/kg	30	/	N.D.
3,3'-Dimethylbenzidine	mg/kg	30	/	N.D.
4, 4'-Diamino-3, 3'-dimethyldiphenyl methane	mg/kg	30	/	N.D.
2-Methoxy-5-methylaniline (Cresidine)	mg/kg	30	/	N.D.
4,4'-Methylenebis(2-chloroaniline)	mg/kg	30	/	N.D.
4,4'-Oxydianiline	mg/kg	30	/	N.D.
4-Aminophenylthioether	mg/kg	30	/	N.D.
o-Toluidine	mg/kg	30	/	N.D.
2,4-Diaminotoluene	mg/kg	30	/	N.D.
2,4,5-Trimethylaniline	mg/kg	30	/	N.D.
2-Methoxyaniline	mg/kg	30	/	N.D.
4-Aminoazobenzene	mg/kg	30	/	N.D.

Note:

- The CAS Number 97-56-3 and 99-55-8 are further reduced to CAS Numbers 95-53-4 and 95-80-7
- Azo colorants that are able to form 4- Aminoazobenzene, generate under the condition of this method aniline and 1,4-phenylenediamine. The presence of these colorants cannot be reliably ascertained without additional information, e.g. the chemical structure of the colorant used.

TEST REPORT

NO.: A002E11110234-1R01

Date: Nov. 10, 2011

Page 11 of 14

Item	Unit	MQL	Acceptable Limit	Results
				2
Methylene chloride (Dichloromethane)	mg/kg	1	/	N.D.
Carbon tetrachloride	mg/kg	1	/	N.D.
Methyl chloroform=1,1,1-Trichloroethane	mg/kg	1	/	N.D.
Halons				
Halon-1211	mg/kg	1	/	N.D.
Halon-1301	mg/kg	1	/	N.D.
Halon-2402	mg/kg	1	/	N.D.
CFC's (Chlorofluorocarbons)				
Group I				
Chlorofluorocarbon-11	mg/kg	1	/	N.D.
Chlorofluorocarbon-12	mg/kg	1	/	N.D.
Chlorofluorocarbon-113	mg/kg	1	/	N.D.
Chlorofluorocarbon-114	mg/kg	1	/	N.D.
Chlorofluorocarbon-115	mg/kg	1	/	N.D.
Group II				
Chlorofluorocarbon-13	mg/kg	1	/	N.D.
Chlorofluorocarbon-111	mg/kg	1	/	N.D.
Chlorofluorocarbon-112	mg/kg	1	/	N.D.
Chlorofluorocarbon-211	mg/kg	1	/	N.D.
Chlorofluorocarbon-212	mg/kg	1	/	N.D.
Chlorofluorocarbon-213	mg/kg	1	/	N.D.
Chlorofluorocarbon-214	mg/kg	1	/	N.D.
Chlorofluorocarbon-215	mg/kg	1	/	N.D.
Chlorofluorocarbon-216	mg/kg	1	/	N.D.
Chlorofluorocarbon-217	mg/kg	1	/	N.D.



TEST REPORT

NO.: A002E11110234-1R01

Date: Nov. 10, 2011

Page 12 of 14

Item	Unit	MQL	Acceptable Limit	Results
				2
HCFC's (Hydrogenated chlorofluorocarbons)				
Hydrogenated chlorofluorocarbons-21	mg/kg	1	/	N.D.
Hydrogenated chlorofluorocarbons-22	mg/kg	1	/	N.D.
Hydrogenated chlorofluorocarbons-31	mg/kg	1	/	N.D.
Hydrogenated chlorofluorocarbons-121	mg/kg	1	/	N.D.
Hydrogenated chlorofluorocarbons-122	mg/kg	1	/	N.D.
Hydrogenated chlorofluorocarbons-123	mg/kg	1	/	N.D.
Hydrogenated chlorofluorocarbons-124	mg/kg	1	/	N.D.
Hydrogenated chlorofluorocarbons-131	mg/kg	1	/	N.D.
Hydrogenated chlorofluorocarbons-131b	mg/kg	1	/	N.D.
Hydrogenated chlorofluorocarbons-133a	mg/kg	1	/	N.D.
Hydrogenated chlorofluorocarbons-141b	mg/kg	1	/	N.D.
Hydrogenated chlorofluorocarbons-221	mg/kg	1	/	N.D.
Hydrogenated chlorofluorocarbons-222	mg/kg	1	/	N.D.
Hydrogenated chlorofluorocarbons-223	mg/kg	1	/	N.D.
Hydrogenated chlorofluorocarbons-224	mg/kg	1	/	N.D.
Hydrogenated chlorofluorocarbons-225ca	mg/kg	1	/	N.D.
Hydrogenated chlorofluorocarbons-225cb	mg/kg	1	/	N.D.
Hydrogenated chlorofluorocarbons-226	mg/kg	1	/	N.D.
Hydrogenated chlorofluorocarbons-231	mg/kg	1	/	N.D.
Hydrogenated chlorofluorocarbons-232	mg/kg	1	/	N.D.
Hydrogenated chlorofluorocarbons-233	mg/kg	1	/	N.D.
Hydrogenated chlorofluorocarbons-234	mg/kg	1	/	N.D.
Hydrogenated chlorofluorocarbons-235	mg/kg	1	/	N.D.
Hydrogenated chlorofluorocarbons-241	mg/kg	1	/	N.D.
Hydrogenated chlorofluorocarbons-242	mg/kg	1	/	N.D.
Hydrogenated chlorofluorocarbons-243	mg/kg	1	/	N.D.
Hydrogenated chlorofluorocarbons-244	mg/kg	1	/	N.D.
Hydrogenated chlorofluorocarbons-251	mg/kg	1	/	N.D.
Hydrogenated chlorofluorocarbons-252	mg/kg	1	/	N.D.
Hydrogenated chlorofluorocarbons-253	mg/kg	1	/	N.D.
Hydrogenated chlorofluorocarbons-261	mg/kg	1	/	N.D.
Hydrogenated chlorofluorocarbons-262	mg/kg	1	/	N.D.
Hydrogenated chlorofluorocarbons-271	mg/kg	1	/	N.D.

TEST REPORT

NO.: A002E11110234-1R01

Date: Nov. 10, 2011

Page 13 of 14

Item	Unit	MQL	Acceptable Limit	Results	
				1	2
PFOA	mg/kg	5	50	N.D.	N.D.
HBCDD	mg/kg	5	1000	/	N.D.
Diarsenic trioxide	mg/kg	50	/	/	N.D.
Diarsenic pentaoxide	mg/kg	50	/	/	N.D.
Boric acid	mg/kg	50	/	/	N.D.
Specific sodium borates	mg/kg	50	/	/	N.D.
Halogen					
Fluorine (F)	mg/kg	50	/	/	N.D.
Chlorine (Cl)	mg/kg	50	900	/	N.D.
Bromine (Br)	mg/kg	50	900	/	1,559
Iodine (I)	mg/kg	50	/	/	N.D.
Antimony (Sb)*	mg/kg	2	/	/	10,751

Specimen Description:

- 1: Metal
- 2: Black plastic

Note:

- Reference information: Directive (EU) No 757/2010
- (i) May not be placed on the market or used as a substance or constituent of preparations in a concentration equal to or higher than 0.001% by mass.
- (ii) May not be placed on the market in semi-finished products or articles, or parts thereof, if the concentration of PFOS is equal to or higher than 0.1% by mass calculated with reference to the mass of structurally or microstructurally distinct parts that contain PFOS or, for textiles or other coated materials, if the amount of PFOS is equal to or higher than $1\mu\text{g}/\text{m}^2$ of the coated material.
- Specimens, which requested to determine Cadmium, Mercury, Lead, Beryllium, Cobalt and Antimony Content, have been dissolved completely.
- *Since through mechanical separation, it couldn't thoroughly separate plastic piece from metal. Thus, the Sb in the plastic
- mg/kg=ppm
- N.D.=not detected(<MQL)
- MQL=Method Quantitation Limit
- Negative=Absence of Cr(VI);
- Positive=Presence of Cr(VI);
- Photo is included

TEST REPORT

NO.: A002E11110234-1R01

Date: Nov. 10, 2011

Page 14 of 14

Photograph of Sample

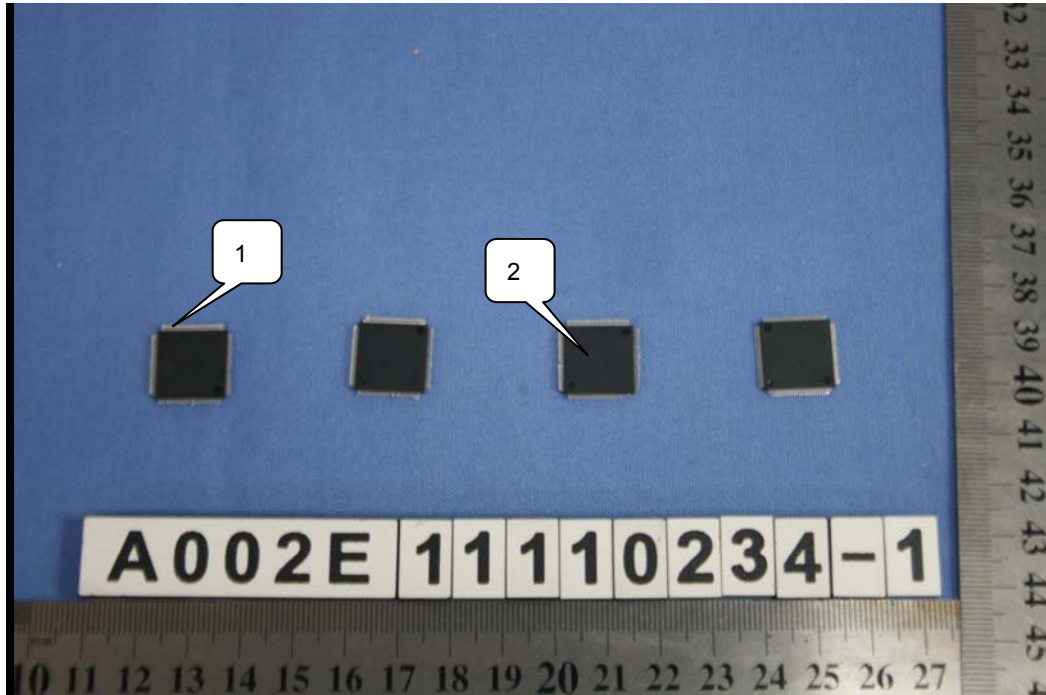

LQFP100-NT

End of Report